

For your automation solutions

Collaborative Automation Partner Program

Length and speed control for textile yarn
winding operations through Modbus interface

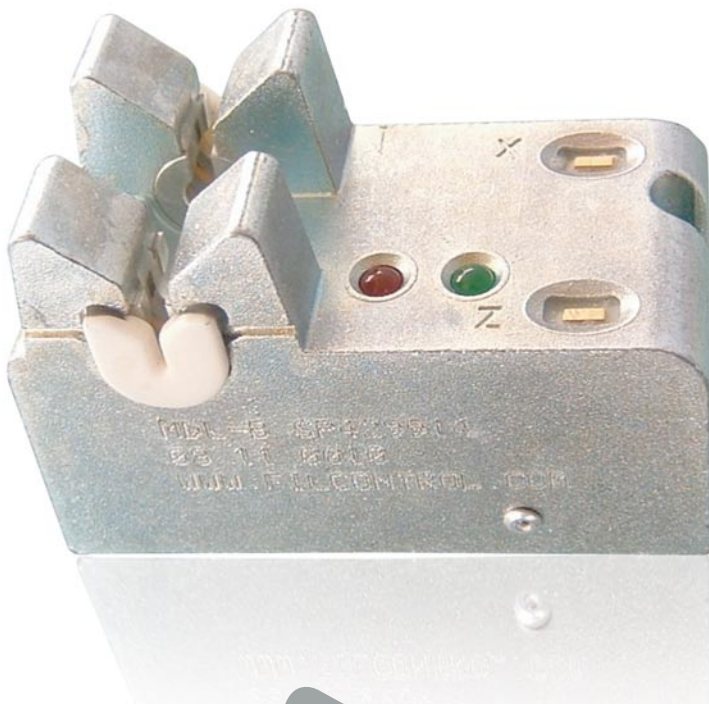

FC FIL CONTROL
Groupe ELSIDEV

Schneider
Electric

Electronic Yarn Length Meter-MDL-B

MDL-B limit length spreading between all bobbins on a complete machine doffing. MDL-B can also be use in order to regulate speed all along winding cycle.

MDL-B Devices for yarn length metering

The heart of system is the DSP (Digital Signal Processor). Using the analog signal DSP calculates delay it take to the yarn to go from one sensor to the other. MDL-B is a stand alone device. Central unit (Panel PC, PLC, ...) is only necessary to set the target lengths or to read current values.

Various parameters can be read, for example :

- > Length
- > Speed
- > Number of yarn breaks
- > Cycle time

MDL-B is equipped with a RS485 Modbus allowing direct communication with Schneider Electric PLC or iPC. In case of power failure, data will be saved allowing the restart current cycle. With its Aluminium alloy housing and its Epoxy resin sealing, MDL-B is intended to bear with harsh industrial environment.



How does MDL-B operate ?

Drawing below illustrates operating principal of MDL-B. When passing inside the sensors, electrostatic charges of the yarn generate signal. The same part of the yarn will create a similar signal in both sensors but with a small time shift. Digital Signal Processor is used to calculate the time shift between the 2 sensor's signals.

Of course the delay is inversely related to the speed. Every 1/2 second a current speed is calculated from the delay and the constant distance between sensors. Internal clock gives the time reference to calculate length evolution at every speed calculation.

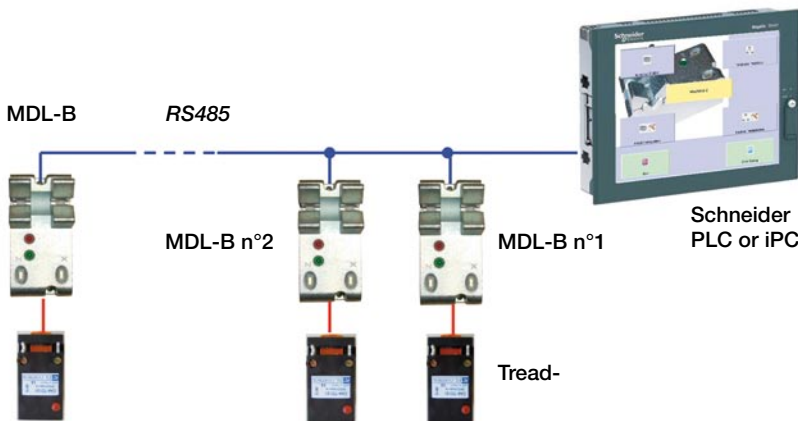
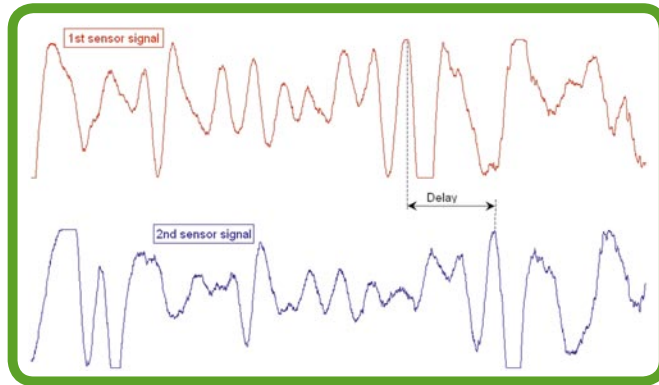

Interface with machine and other accessories

2 power outputs (1 NPN or PNP + 1 relay) are available to drive a thread-cutter, to stop the spindle. 2 inputs give the possibility to synchronise with machine cycle. An RS485 serial interface allows the communication with Schneider's PLCs or iPC through Modbus protocol.

MDL-B versus mechanical systems

There are several ways to measure length and speed with mechanical systems. Such mechanical systems operate by counting revolution number of a motor drum or sensing pulley. MDL-B is a non contact measurement system that having several benefits by comparison with mechanical type. Depending of spin finish and yarn strain some slippage can occur between yarn and drum,

creating a loss of accuracy. Ageing and spin finish will affect the friction torque of pulley bearing increasing the risk of slippage between yarn and wheel. This will also create a loss of accuracy and will require some maintenance operation. A third problem may appear when dust accumulation will clog the pulley groove increasing pulley diameter and so false the measurement.

Electronic Yarn Length Meter - MDL-B

The MDL-B is a highly integrated speed and length controller based on the Digital Signal Processor.

- > Offer to the customers High Quality Bobbins
- > Reducing the waste level of yarns
- > Minimise the cycle times
- > No mechanical parts
- > Easy to install and Friendly to use
- > Adapted to automatic system



More service with Schneider Electric's worldwide coverage

> Permanent worldwide availability

With over 5000 sales outlets in 130 countries, wherever you are you can be sure of finding a full range of products to meet your needs and fully compliant with the standards in your country.

> Technical support

Wherever you are Schneider Electric provides technical support around the world. What's more, Schneider's experts are at hand to work out a customized solution with you.



Groupe ELSIDEV

FIL CONTROL SAS is a French private Company,

founded 16 years ago, when the owner bought the textile activity of TELEMECANIQUE. FIL CONTROL SAS develops, produces and sells yarn sensors, yarn cutters and QC devices for the Yarn Textile Industry.

Particularly it offers new developments (OEM) and machines conversion. FIL CONTROL SAS founded in 2004 a subsidiary in China, FIL CONTROL Co. Ltd. (WUHU/ANHUI Province).

FIL CONTROL SAS are represented abroad through a dozen of Partners (Colombia, Egypt, Italy, Pakistan, Poland, Republic Czech, Slovakia, Spain, Turkey, Taiwan, and USA). Our customers include the largest machine builders as well as end-users and converters.

Collaborative Automation
by



> Make the most of your energy